

Air Heater & Blower - Process Heat -

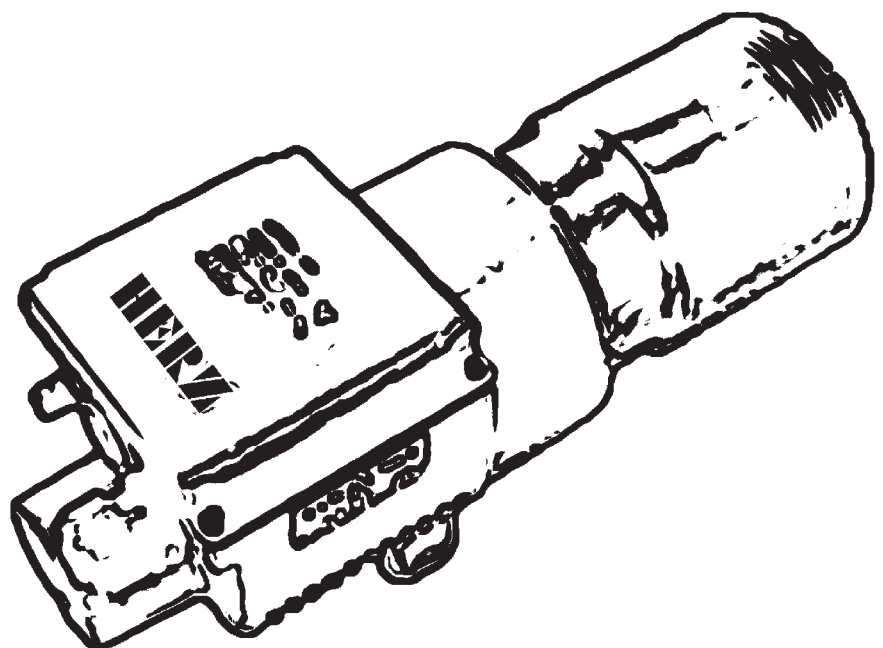
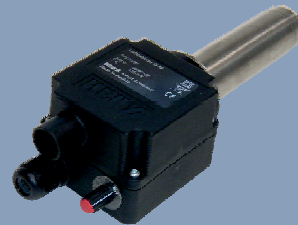

Air heaters from 450 Watt to 21000 Watt

INNOVATIVE

Highly versatile due to its modular structure; modern and primarily functional design; equipped with electronic heating element and device protection (S, M, L, XL and Compact);

PRACTICE-ORIENTED

Type XS, S, and M:

Approved configuration and dimensions; flexible due to graded heating elements; control via potentiometer, regulator or PLC;

Type L and XL:

With or without power divider; with power control via potentiometer, regulator or PLC; control configuration can be modified at each service point; device protection evaluable via potential-free contact;

SERVICE-ORIENTED

Reliable service within 24 hours; easy replacement of heating elements by the user;

Calculation of air heaters

1. Heat requirement calculation

Formula: $Q = m \cdot c \cdot \Delta t$

Q = Heat quantity in Kj (Kilojoule)
 m = Mass in kg
 C = Specific heat capacity in Kj/kg.K
 (see value table)
 Δt = Temperature rise (target temperature – starting temperature)

2. Conversion

Formula: $P = Q/3600$

P = Power in KWh
 Q = Heat quantity in Kj (Kilojoule)

Value table	Heat capacity (C)	Heat of fusion (Lf)= Kj/kg	Heat of evaporation (Lv) = Kj/kg
Aluminium	0,896	355,9	11723
Lead	0,13	23,86	921,1
Iron (pure)	0,44	272,1	6364
Gold	0,13	66,99	1758
Graphite	0,712	16750	50242
Constantan	0,41		
Copper	0,381	209,3	4647
Brass	0,389	167,5	
Nickel	0,452	293,1	6196
Platinum	0,134	113	2512
Silver	0,234	104,7	2177
Silicon	0,741	141,5	14068
Tungsten	0,134	191,8	4815
Tin	0,23	58,62	2596
Alcohol	2,428	104,7	858
Benzene	1,738	127,3	389
Machine oil	1,675		
Mercury	0,138	11,72	301
Sulphuric acid	1,382	108,9	511
Water	4,187	333,7	2258
Ammonia	2,06	339,1	1369
Carbon dioxide	0,825	184,2	574
Air	1,001		197
Nitrogen	1,043	25,96	199
Hydrogen	14,24	58,62	461

The efficiency must be considered on the basis of radiation and exhaust air temperature.

Type Compact

from 2300 Watt to 6100 Watt

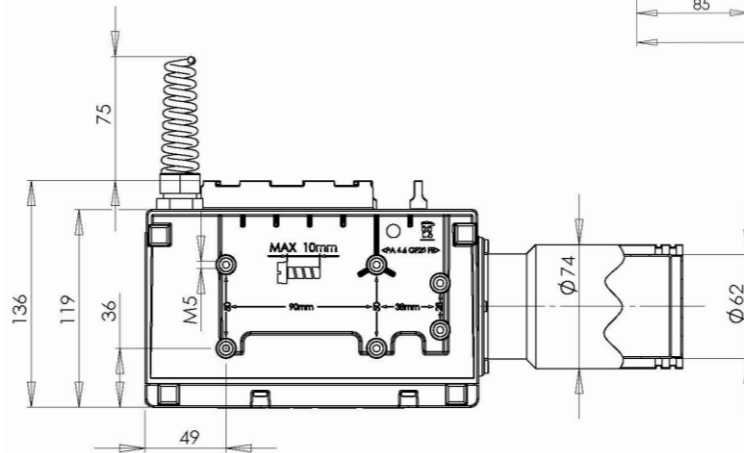
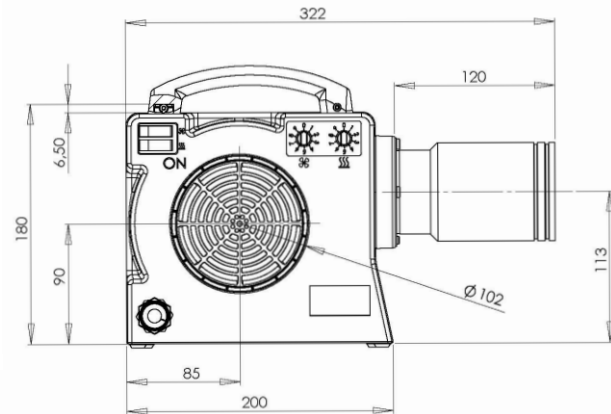

Unsurpassed in air quantity and air pressure at extremely small dimensions!

Infinitely variable temperature settings and an electronic heating element and device protection is standard on this device, as well as the infinitely variable speed control for variable air quantities. Temperature and rotational speed are set via the potentiometer. Optionally, both values can also be selected via an external control (e.g. PLC).

Rotational speed can also be requested for process safety visualization or monitoring.

A comprehensive scope of accessories enables the device to be used for many applications. Due to its small dimensions of maximum 360x138x180, Compact offers a space-saving and versatile range of installations. The six cast metal threads on the bottom enable a trouble-free assembly in all operating positions as well as easy exchange.

TECHNICAL DATA	Type Compact	C-2300	C-3100	C-3700	C-4700	C-6100
Item number		5102586	5102602	5102581	5102605	5102599
Voltage	VAC		230		400 (2Ph + N)	
Frequency	Hz			50 / 60		
Power	kW	2,3	3,1	3,7	4,7	6,1
Current	A	10	13,5	16	11,8	15,3
Max. temperature	°C	650	800		650	
Min. air quantity	l/min	400	350	400		550
Max. air quantity at 20°C	l/min	940	800	930	960	950
Max. temperature with full air quantity	°C	260	520	440	480	630
Static pressure	Pa			450		
Sound pressure level (LpA)	db			73 (at distance of 1m)		
Intake opening Ø	mm			102,5		
Heating element tube Ø	mm			62/74		
Dimensions (L x W x H)	mm	322 x 138 x 180	360 x 138 x 180	322 x 138 x 180	360 x 138 x 180	
Weight incl. cable	kg	2,8	3,1	2,8	3,1	
Conformity mark						
Protection class II						

Type XS20

from 450 Watt to 2000 Watt

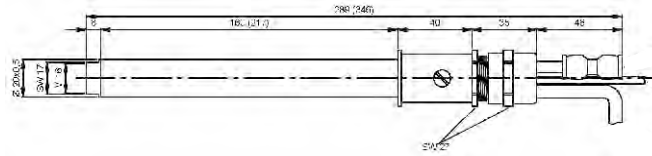

TECHNICAL DATA	Air heater - Type	XS20-400TC	XS20-800TC	XS20-1000TC	XS20-1500TC	XS20-2000TC
Item number		5202412	5202414	5202416	5202418	5202420
Voltage	VAC			230		
Frequency	Hz			50 / 60		
Power	KW	0,45	0,8	1,0	1,5	2,0
Current	A	1,7	3,5	4,4	6,5	8,8
Max. temperature	°C			650		
Min. air quantity	l/min	30	60	75	100	150
Max. pressure supply air	bar			6,0		
Thermocouple	Typ			,K'		
Weight	kg		0,4			0,5
Air connection	Ø mm			Push-in plug 6mm		
Exhaust opening	Ø mm			M16 internal thread; SW 17		
Dimensions	mm(L x Ø)		283 x 30		340 x 30	
Conformity mark						
Protection class I						

Type XS21

to 800 Watt

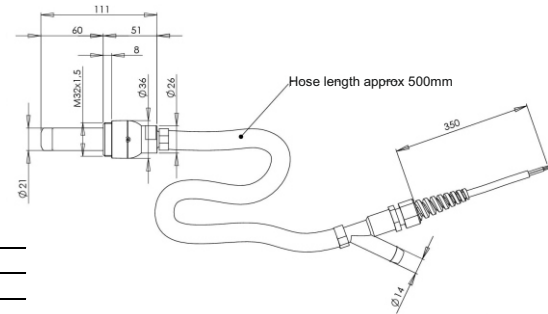

Technical Data:

Art. No.		On request	5202431	
Voltage	VAC	120	230	
Frequency	Hz		50 / 60	
Power output	KW	0.55	0.435	0.8
Power	A	4.6	1.9	3.5
Max. temperature	°C		600	
Min. volume of air	l/min	150	100	170
Weight	kg		0.3	
Air inlet	Ø mm		14	
Exhaust outlet	Ø mm		15	
Heating element tube	Ø mm		21	
Measurements excluding hose	mm (L x Ø)		131x36.5	
Mark of conformity				
Protection class II				

Type S21

from 435 Watt to 800 Watt

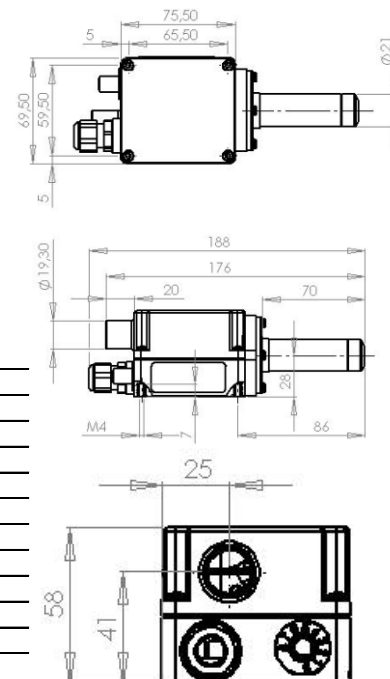

TECHNICAL DATA	Air heater - Type	S21 - 435	S21 - 800
Item number		On request	5101351
Voltage	VAC		230
Frequency	Hz		50 / 60
Power	KW	0,435	0,8
Current	A	1,9	3,5
Max. temperature	°C		600
Min. air quantity	l/min	120	210
Weight	kg		0,3
Air intake	Ø mm		19
Exhaust opening	Ø mm		13
Heating element tube	Ø mm		21
Dimensions	mm (L x W x H)		188 x 69,5 x 58
Conformity mark			
Protection class II			

Type S32

from 1550 Watt to 2000 Watt

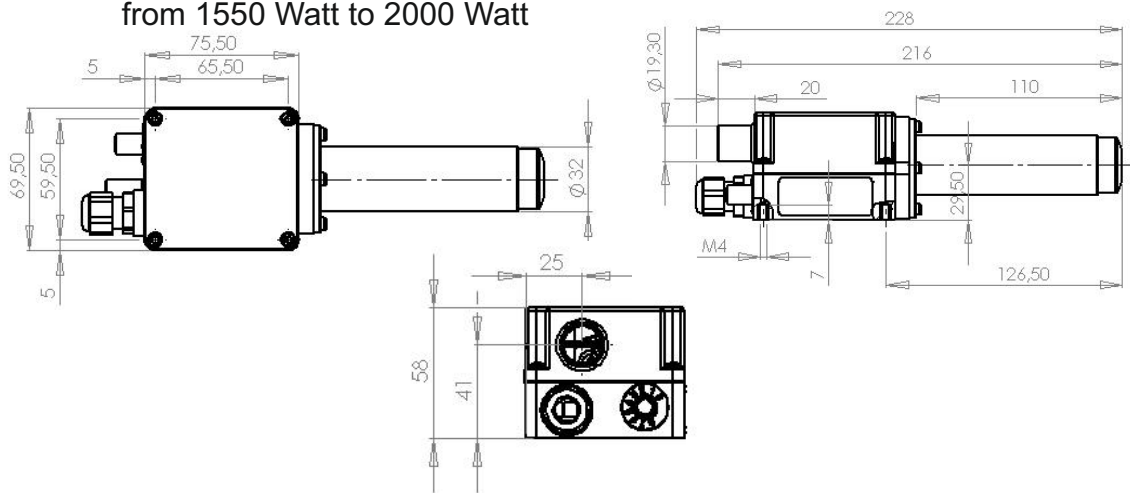

TECHNICAL DATA

Air heater - Type

S32 - 1550

S32 - 2000

Item number	5101355		5101357
Voltage	VAC	230	
Frequency	Hz	50 / 60	
Power	KW	1,5	2,0
Current	A	6,7	8,7
Max. temperature	°C	650	
Min. air quantity	l/min	200	260
Weight	kg	0,4	
Air intake	\varnothing mm	19	
Exhaust opening	\varnothing mm	16	
Heating element tube	\varnothing mm	32	
Dimensions	mm (L x W x H)	228 x 69,5 x 58	
Conformity mark			
Protection class II	<input type="checkbox"/>		

Type S36

from 2300 Watt to 3300 Watt

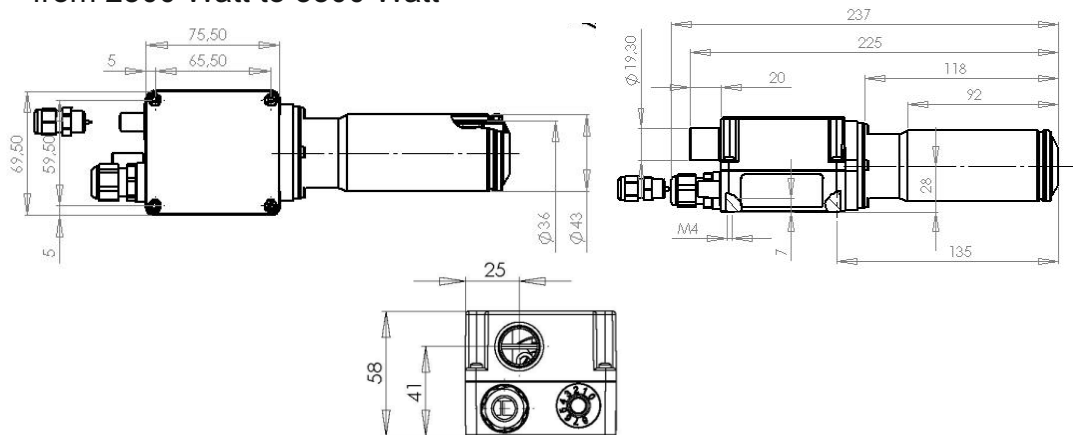

TECHNICAL DATA

Air heater - Type

S36 - 2300

S36 - 3300

Item number	5101428		5101426
Voltage	VAC	230	
Frequency	Hz	50 / 60	
Power	KW	2,3	3,3
Current	A	10,0	14,4
Max. temperature	°C	650	
Min. air quantity	l/min	240	370
Weight	kg	0,47	
Air intake	\varnothing mm	19	
Exhaust opening	\varnothing mm	22	
Heating element tube	\varnothing mm	36 / 43	
Dimensions	mm (L x W x H)	237 x 69,5 x 58	
Conformity mark			
Protection class II	<input type="checkbox"/>		

Type M50 und M50L

from 2200 Watt to 7400 Watt

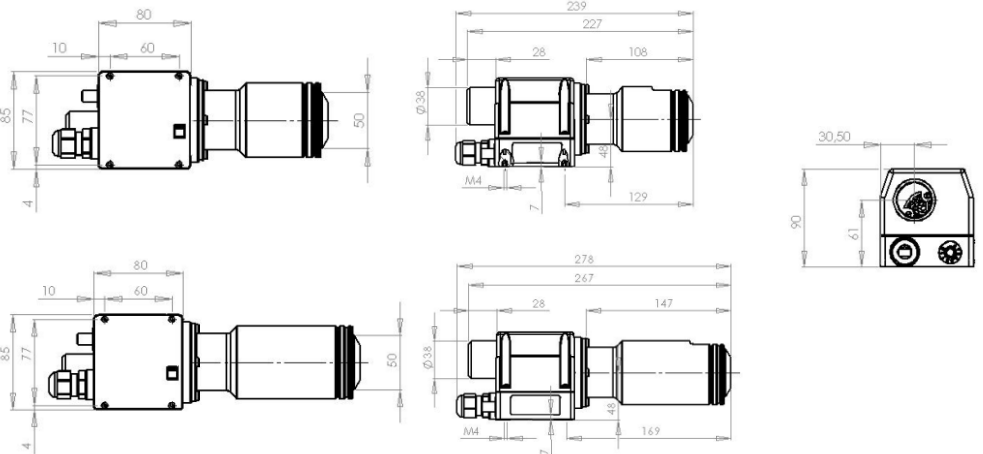

TECHNICAL DATA	Air heater - Type	M50 - 2200	M50 - 3700	M50 - 4500	M50L - 4600	M50L - 6100
Item number		5101801	5101796	5101806		5112688
Voltage	VAC	230		400 (2Ph)	400 – 440 (2 Ph)	
Frequency	Hz			50 / 60		
Power	KW	2,2	3,7	4,5	4,6 -5,57	6,1 – 7,4
Current	A	9,6	16,2	11,2	11,5 – 12,7	15,3 – 16,8
Max. temperature	°C			650		
Min. air quantity	l/min	160	290	370		540
Weight	kg	0,8				0,9
Air intake	Ø mm			38		
Exhaust opening	Ø mm			30		
Heating element tube	Ø mm			50 / 65		
Dimensions	mm (L x W x H)	239 x 85 x 90			278 x 85 x 90	
Conformity mark						
Protection class II						

Type L62

from 4300 Watt to 9200 Watt

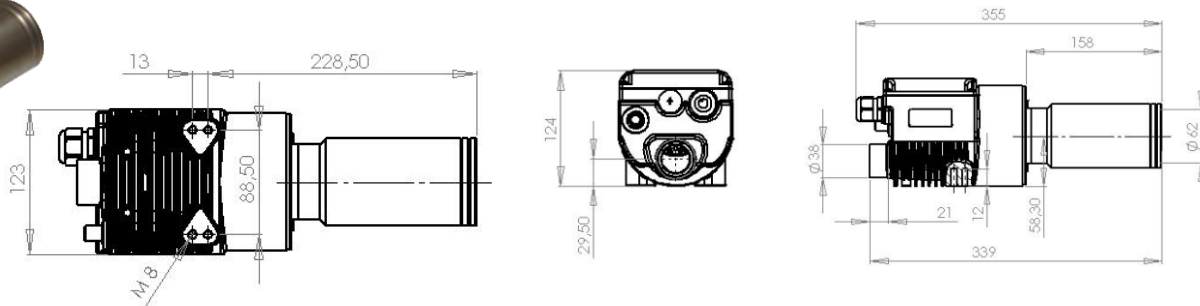

TECHNICAL DATA	Air heater - Type	L62 - 4300	L62 - 5800	L62 - 8600	L62 - 9100	L62 - 4400	L62 - 7600
Item number		5102156	5102169	5102174	5100989	5102171	5102175
Voltage	VAC	230	400 – 440 (2 Ph)			400 - 440	
Frequency	Hz			50 / 60			
Power	KW	4,3	5,8 – 7,0	8,6 – 10,5	9,1 – 11,0	4,4 -5,3	7,6 -9,2
Current	A	18,6	14,5 – 15,9	21,6 – 23,9	22,7 – 25,0	6,3 – 7,0	11,0 – 12,0
Max. temperature	°C			700			
Min. air quantity	l/min	240	390	470	680	270	550
Weight	kg			2,9			
Air intake	Ø mm			38			
Exhaust opening	Ø mm			55			
Heating element tube	Ø mm			62 / 74			
Dimensions	mm (L x W x H)			355 x 123 x 124			
Conformity mark							
Protection class I							

Type XL92

from 5900 Watt to 21000 Watt

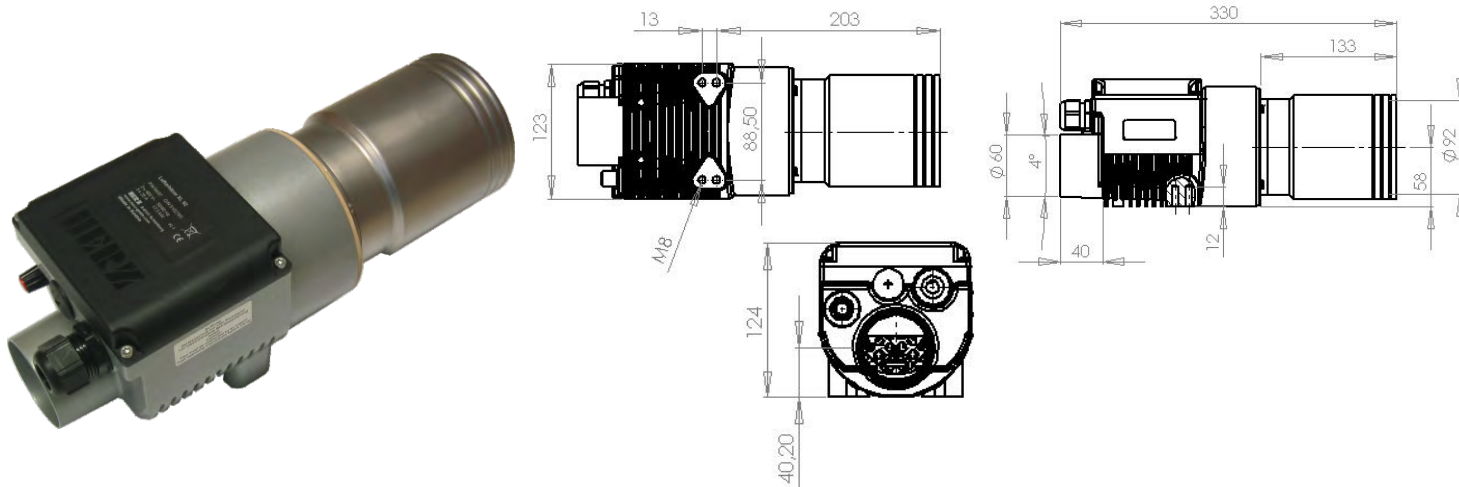

TECHNICAL DATA	Air heater - Type	XL92 - 5900	XL92 - 7600	XL92 - 11800	XL92 - 17400
Item number		5102761	5102762	5102760	5102765
Voltage	VAC	400 - 440			
Frequency	Hz	50 / 60			
Power	KW	5,9 - 7,1	7,6 - 9,2	11,8 - 14,3	17,4 - 21,0
Current	A	8,5 - 9,4	10,9 - 12,0	17,1 - 18,7	25,1 - 27,6
Max. temperature	°C	650			
Min. air quantity	l/min	370	490	760	1140
Weight	kg	3,3			
Air intake	Ø mm	60			
Exhaust opening	Ø mm	84			
Heating element tube	Ø mm	92 / 102			
Dimensions	mm (L x W x H)	330 x 123 x 124			
Conformity mark					
Protection class I					

Type PH62 and PH92

from 4400 Watt to 21000 Watt

Both devices are provided with flanges on the inlet and the outlet side and can therefore be easily integrated into a tube system. In recirculating air mode, supply air temperatures can be located at the air intake without causing damage. The tube air heaters are designed for a high system pressure and can therefore also be used in closed systems.



TECHNICAL DATA	Air heater - Type	PH62 - 4400	PH62 - 7600	PH92 - 5900	PH92 - 11800	PH92 - 17400
Item number		5114352	5114702	On request	5114354	On request
Voltage	VAC	400 - 440 - 480				
Frequency	Hz	50 / 60				
Power	KW	4,4 - 5,3	7,6 - 9,2	5,9 - 7,1	11,8 - 14,3	17,4 - 21,0
Current	A	6,3 - 7,0	11,0 - 12,0	8,5 - 9,4	17,1 - 18,7	25,1 - 27,6
Max. temperature	°C	650				
Min. air quantity	l/min	450	710	550	950	1480
Weight	kg	3,3				
Air intake	Ø mm	86			113	
Exhaust opening	Ø mm	60			90	
Dimensions	mm (L x W x H)	184 x 116 x 137			165 x 146 x 170	
Conformity mark						
Protection class I						

Type PN10

from 3300 Watt to 14300 Watt



Compressed air up to 10 bar - without any problems

Due to its small dimensions, the gas-tight air heater can be installed with minimum space requirements.

One or several devices connected to the compressed air network provide an air flow with high air speed. The temperature is 100% electronically controllable. The hot air jet is used in drying processes, soldering, and much more.

Due to its stable design, this device is suitable even for the toughest operation (i.e. foundries).

<u>TECHNICAL DATA</u>	Air heater - Type	PN10 - S	PN10 - M		PN10 - XL
Item number		5201190	5201191	5201192	5201193
Voltage	VAC	230		400 (2 Ph)	400 - 440
Frequency	Hz	50 / 60			
Power	KW	3,3	3,7	4,5	11,8 – 14,3
Current	A	14,4	16,1	11,2	17,1 – 18,7
Max. temperature	°C	650			
Min. air quantity	l/min	420	360	490	760
Max. pressure supply air	bar	10,0			
Weight	kg	4,7	16,5	24,0	
Air connection	Ø inch	1/2"	1"	2"	
Exhaust opening	Ø inch	1/2"	1"	2"	
Dimension	mm (L x Ø)	350 x 160	442,5 x 285		575 x 340
Conformity mark					
Protection class I					

Examples of use:

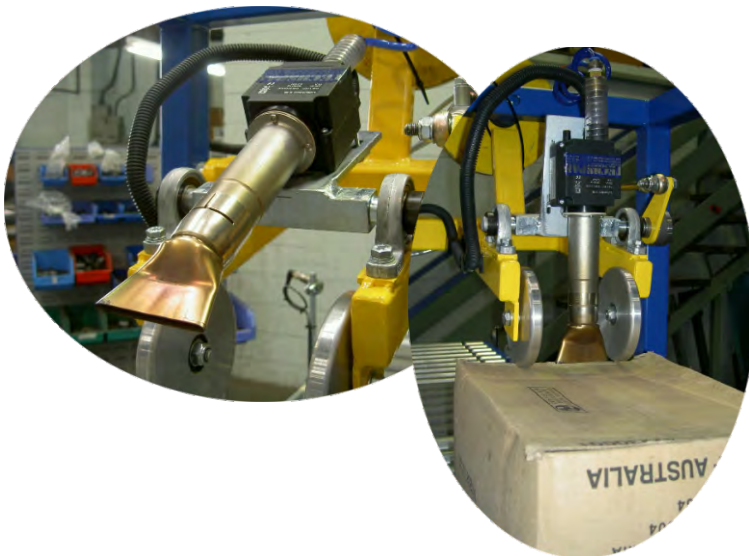

Air heater S36 with carton gluing device.

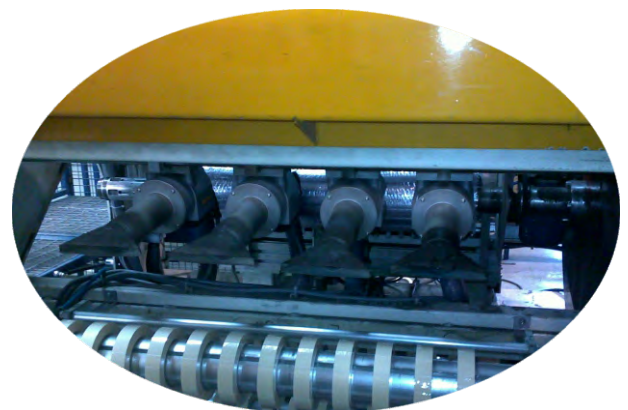

Air heater L62 in the range of applications.

Type HD140

1,45 m³ / min - 14000 Pa

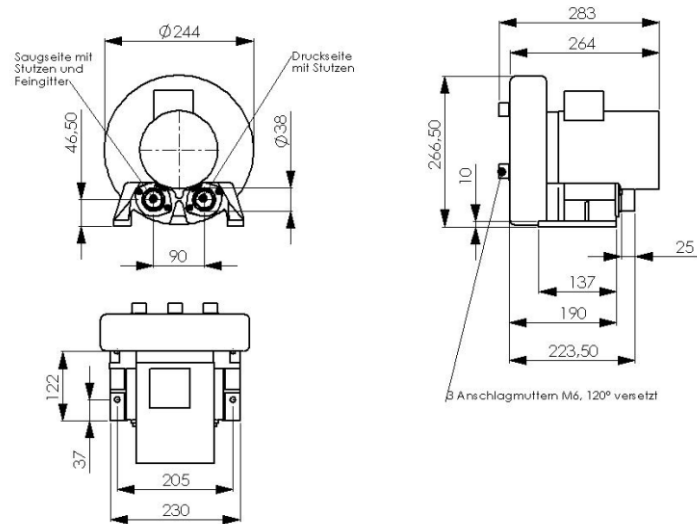

Design: Side channel blower

Item No.: 5103429

Volumetric current	Overall pressure difference	Voltage	Frequency	Current consumption	Speed	Motor power	Noise pressure level	Weight
m ³ / min	Pa	V	Hz	A	rpm	KW	LpA (db)	kg
1,45	14000	200 - 255 346 - 440	50	1,90 - 2,45 1,10 - 1,40	2825	0,44	65	11,3
1,7	14500	200 - 277 346 - 480	60	2,25 - 2,10 1,30 - 1,20	3410	0,56	70	11,3

Intake port : $\varnothing 38$ mm (exterior)

Discharge port : $\varnothing 38$ mm (exterior)

Dimensions (lxwxh) : 283 x 244 x 266.5

Ambient temperature : -20°C to +60°C

Type of protection : IP 54

Optionally 1 x 230 V : Capacitor 230 V; 40 μ F / V (5108623)

Type HD240

3,65 m³ / min - 27000 Pa

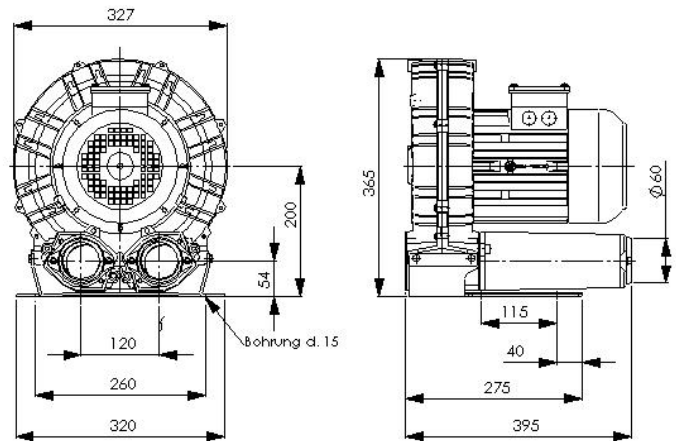

Design: Side channel blower

Item No.: 5100200

Volumetric current	Overall pressure difference	Voltage	Frequency	Current consumption	Speed	Motor power	Noise pressure level	Weight
m ³ / min	Pa	V	Hz	A	rpm	KW	LpA (db)	KG
3,65	27000	230 - 400	50	5,1	2900	2,20	68,8	26,5
4,42	26000	265 - 460	60	5,1	3500	2,55	70,8	26,5

Intake port : $\varnothing 60$ mm (exterior)

Discharge port : $\varnothing 60$ mm (exterior)

Dimensions (lxwxh) : 397 x 327 x 365

Ambient temperature : -20°C to +60°C

Type of protection : IP 54

Our high pressure blowers are characterized by:

High performance with compact design
 Long service life at low operating costs
 Low noise level

- Maintenance-free
- Compact design
- Absolutely oil-free

Type MD10

4,9 m³ / min - 1000 Pa



CE

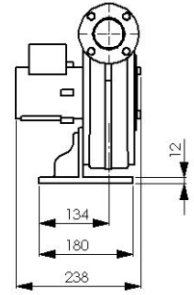
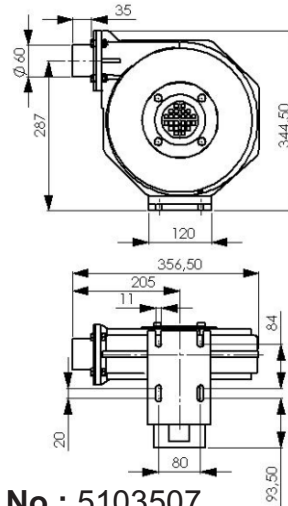

Design: Centrifugal blower

Item No.: 5103507

Volumetric current	Overall pressure difference	Voltage	Frequency	Current consumption	Speed	Motor power	Noise pressure level	Weight
m ³ / min	Pa	V	Hz	A	rpm	KW	LpA (db)	KG
4,9	1000	200 - 277	50	0,45-0,48	2750	0,075	73	8,5
		345 - 480		0,26-0,28				
5,9	1600	200 - 277	60	0,59-0,55	3120	0,140	76	8,5
		345 - 480		0,34-0,32				

Intake port : Ø 70mm
Discharge port : Ø 60 mm (exterior)
Dimensions (lxwxh) : 231 x 356.5 x 344.5

Ambient temperature : -20°C to +60°C
Type of protection : IP 54
Optionally 1 x 230 V : Capacitor 230 V; 8 µF / V (5110887)

Type MD14

16,5 m³ / min - 1400 Pa



CE

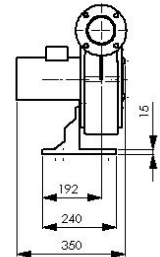
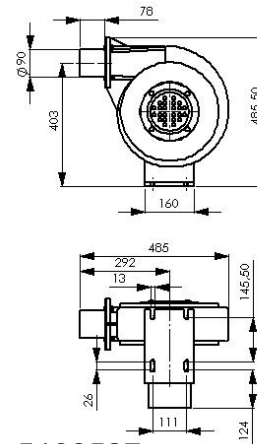

Design: Centrifugal blower

Item No.: 5103527

Volumetric current	Overall pressure difference	Voltage	Frequency	Current consumption	Speed	Motor power	Noise pressure level	Weight
m ³ / min	Pa	V	Hz	A	rpm	KW	LpA (db)	KG
16,5	1400	200 - 277	50	1,55-2,60	2825	0,37	76	17,0
		345 - 480		0,90-1,50				
19,5	2000	200 - 277	60	2,25-2,00	3340	0,55	77	17,0
		345 - 480		1,30-1,15				

Intake port : Ø 125mm
Discharge port : Ø 90 mm (exterior)
Dimensions (lxwxh) : 345 x 485 x 485.5

Ambient temperature : -20°C to +60°C
Type of protection : IP 54
Optionally 1 x 230 V : Capacitor 230 V; 30 µF / V (5103523)

Our medium pressure blowers are characterized by:

- High performance with compact design
- Appropriate performance scaling
- Long service life at low operating costs
- Excellent efficiency
- Favourable noise characteristics

- Sturdy and streamlined case designs
- Maintenance-free
- Compact design
- Absolutely oil-free

Frequency converter series SK

**COMMANDER SK - EASY AND COMPACT DESIGN,
BUT STILL POWERFUL**



SK220 Art.-No. 5117360 SK75 Art.-No. 5117359

- Easy to parameterize - all parameters required for typical applications are displayed on the front bezel - it couldn't be easier
- Easy to install - you can choose between the simple wall mounting and the DIN rail mounting (up to 1.5 kW / 2hp)
- Easy connections - easily accessible connection terminals with clear labelling
- Easy to start - settings at the touch of a button - complex programming is not required
- Built-in EMV filter - can be switched off if needed
- Control unit with display as standard
- Software and documentation CD included in the standard pack
- Communication interface RS485 - Modbus RTU as standard protocol
- Extraordinary level of performance

TYPE ETR48-24

Ideal for temperature regulations with [HERZ air heaters](#)

The regulators of the ETR series are versatile PID temperature regulators in standard DIN format 1/32 (ETR48-24) and 1/16 (ETR48-48) with self-optimization.

Universal input

Different temperature inputs: thermocouple, platinum resistance thermometer, infrared thermometer as well as analogue inputs.

Optimization

Auto-adaptation and self-optimization available. Auto-adaptation is possible even during self-optimization execution.

Safety / Certificates

Waterproof front construction (NEMA4X; corresponds to IP66). Corresponds to safety regulations UL, CSA, and IEC and is marked with the CE symbol.

Digital communication (optional)

RS485 enables easy parameterization via notebook / PC.

Exact regulation

A reliable PID control algorithm enables a stable and "straight" process regulation.

Universal input

The ETR48-48 universal input circuit is provided with an analogue / digital converter. It scans the input with 9 Hz and constantly corrects the drift. This ensures high process stability and fast response to changes.

Easy handling

A bright and clearly visible LED display shows the actual value as well as error messages. The target value can be modified by pressing the "more" or "less" button.

Digital communication (optional)

Communication interface RS485, RS422 or RS232 supports Modbus®, DeviceNet®.



Art.-No.: 5202408



Thermocouple item no.: 5106956
Extension balancing line item no.: 5106957

Thermocouple

Thermocouples type 'K' are reliable and solid. With a sensor length of about 122 mm, the probe can also be positioned in inaccessible positions.

The PTFE balancing line has a standard length of 2.0 metres and is provided with a miniature connector.

If an extension of the balancing line is required, please do only tell us the desired length.

IR temperature sensor

- One of the world's smallest infrared measuring heads with max. 20:1 optical resolution; standard resolution 15:1
- Solid and applicable without cooling at up to 180°C ambient temperature
- Separate electronics with easily accessible programming buttons and backlit LCD display
- Selectable analogue output: 0/4-20 mA, 0-10 V, thermocouple type K or J
- USB, RS485, RS232 interface and two potential free relay outputs as an option
- Programming of the analogue and digital input for external emissivity adjustment and background radiation compensation
- Installation and addressing of max. 32 sensors in one network (using RS485)
- Easy parameterization and remote monitoring of the sensor (software)
- Automatic date recording for future analysis and documentation (software)
- Graphical display of temperature curves (software)
- Adjustment of advanced signal processing functions (software)

Art.-No.: 5202116

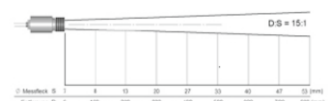

Air flow monitor type M2 COMPACT (DC)



Art.-No.: 5202110

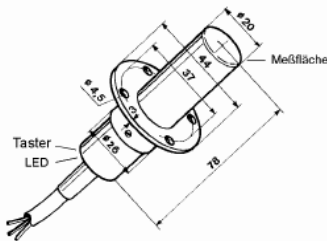

One-piece sensor for monitoring aeriform and gaseous flows by means of integrated evaluation electronics. Due to its teach-in function, the calorimetric device ensures maintenance-free operation.

!!! Important note!!!

Please note that the operation of hot air blowers is only permissible pursuant to VDE 0100 when the air supply is monitored reliably. **Please observe the following excerpt from the VDE 0100, Part 420, DIN 57100, Section 6.1.1:**
„Blower-type heating systems must be erected in such a way that their heating units are not activated until the required air flow has been reached (does not apply to thermal storage heaters).”

Air quantity regulator - manual control

Manual air quantity regulator for connection to blower flange on pressure side to HERZ high and medium pressure blowers.

Item No.	Description
5108755	Manual air volume control for 38/40 mm hose
5107295	Manual air volume control for 60/62 mm hose











Air supply cut-off switch - pneumatic





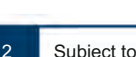

Pneumatic air supply cut-off switch for connection to blower flange on pressure side to HERZ high and medium pressure blowers.

Item No.	Description
5107299	Pneumatic air supply shut-off mechanism for 38/40 mm hose
5107296	Pneumatic air supply shut-off mechanism for 60/62 mm hose
5202404	Air tube 4/2 mm PE











Nozzles for air heater type S21 - S36

	Description	Art.-No.
	Flange connection S21	5107282
	Flange connection S32	5107283
	Flange connection S36	5107250
	Tubular nozzle Ø 5mm S21	5107144
	Tubular nozzle Ø 10mm S21	5107145
	Tubular nozzle Ø 5mm S32	5100303
	Tubular nozzle Ø 5mm S36	5107155
	Flat sheet die 20 x 2mm S32	5105475
	Flat sheet die 40 x 2mm S32	5105526
	Angle nozzle 90°; Ø 12mm S36	5107003
	Extension tube 210 x 36.5mm S36	5107251
	Flat sheet die 70 x 4mm S36	5107261
	Spoon reflector Ø 13mm for soldering solder-shrink connections and for PVC shrinking; PTFE, FEP shrink tubing; slidable onto a round nozzle Ø 5mm	5107324





Nozzles for air heater type M50 and M50L

	Description	Art.-No.
	Flange connection	5107254
	Angle nozzle Ø 50mm; leg length 160 x 100mm	5107256
	Extension tube 36.5 x 160mm	5107255
	Flat sheet nozzle 70 x 10mm	5107258
	Flat sheet nozzle 150 x 12mm	5107270

Nozzles for Compact and air heater type L62

	Description	Art.-No.
	Flange connection	5107246
	Round nozzle Ø 40mm	5107245
	Angle nozzle Ø 62mm; leg length 120 x 112mm	5107265
	Extension tube Ø 40mm; length = 200mm	5107247
	Jet nozzle 700 x 550 x 1.7mm	5107253
	Flat sheet die 85 x 15mm	5107260
	Flat sheet nozzle 150 x 12mm	5107259
	Flat sheet nozzle 200 x 9mm	5105977
	Flat sheet nozzle 250 x 12mm	5107263
	Flat sheet nozzle 300 x 4mm	5107262
	Flat sheet nozzle 500 x 4mm	5105991
	Shell reflector 50 x 400mm; nozzle laterally mounted	5106177
	Stainless steel filter for Compact suction side	5107248

Nozzles for air heater type XL92

	Description	Art.-No.
	Flange connection, slidable	5107275
	Round nozzle Ø 50mm, slidable	5107244
	Angle nozzle Ø 92mm; leg length 175 x 175mm, slidable	5107269
	Extension tube 500 x 60mm, slidable	5107273
	Jet nozzle 1288 x 1000 x 1.5mm (L1 x L2 x W), slidable	5107268

Nozzles for air heater type XL92

	Description	Art.-No.
	Flat sheet nozzle 130 x 17mm	5107274
	Flat sheet nozzle 300 x 12mm	5107272
	Flat sheet nozzle 400 x 10mm	5106018
	Flat sheet nozzle 500 x 15mm	5107267
	Flat sheet nozzle 600 x 4mm	5106023

Distributor, hose and various accessories for all fans

	Description	Art.-Nr.
	Motor capacitor 230 V ~ with clamp and cable for HD140	5108623
	Motor capacitor 230 V ~ with clamp and cable for MD10	5110887
	Motor capacitor 230 V ~ with clamp and cable for MD14	5103523
	Hose connection adaptor 1 x 90mm inside / 2 x 60mm outside	5107238
	Hose connection adaptor 1 x 60mm inside / 2 x 60mm outside	5107278
	Hose connection adaptor 1 x 38mm inside / 2 x 38mm outside	5107293
	Hose connection adaptor 1 x 38mm / 2 x 38mm outside - with thread outside	5207293
	Hose connection adaptor 1 x 60mm inside / 1 x 38mm outside	5107291
	Hose connection adaptor 1 x 38mm inside / 2 x 19mm outside	5107298
	Hose connection adaptor 1 x 38mm inside / 3 x 14mm outside	5107281
	PVC air hose - Ø 60mm inside	5107288
	PVC air hose - Ø 38mm inside	5107286
	PVC air hose - Ø 19mm inside	5107350
	Hose clip for hose Ø 60mm	5107285
	Hose clip for hose Ø 38mm	5107287
	Hose clip for hose Ø 19mm	5107290
	Blowing-off nozzle l = 300mm; outlet opening adjustable; connector Ø 60mm outside; for air heater type L62 and high pressure blower type HD240	5125907
	Blowing-off nozzle l = 500mm; outlet opening adjustable; connector Ø 60mm outside; for air heater type L62 and high pressure blower type HD240	5125908
	Closure cap for hose connection adaptor Ø 60mm	5107240
	Closure cap for hose connection adaptor Ø 38mm	5107241
	Closure cap for hose connection adaptor Ø 19mm	5107242
	Stainless steel filter for HD140, slidable	5107354
	Stainless steel filter for HD240, slidable	5110895
	Intake socket for MD10	5013402
	Intake socket for MD14	5113402
	Paper filter for MD10	5100620

No CD ???

If you need a CD-ROM with detailed technical data and dimensional drawings, please contact us.



You can find us here...

Herz GmbH

Kunststoff- & Wärmetechnologie
Biberweg 1
DE - 56566 Neuwied
Tel.: +49 (0)2622-81086 Fax: +49 (0)2622-81080
www.herz-gmbh.com, info@herz-gmbh.com

Herz Austria GmbH

Kunststoff- & Wärmetechnologie
Gleinser Weg 27
AT - 6141 Schönberg / Tirol
Tel.: +43 (0)5225-63113 Fax: +43 (0)5225-6311385
www.herz-austria.at, herz.schoenberg@herz-gmbh.com

Herz Hungária Kft.

Műanyag- és hőlégtéchnika
Pesti út 284. (HRSZ.3335.)
HU – 2225 Üllő
Tel.: +36 (06)29-522 400 Fax: +36 (06)29-522 410
www.herz-hungaria.hu, herz@herz-hungaria.hu

Herz Bulgaria OOD

Boul. Assen Yordanov 10
BG – 1592 Sofia
Tel.: +359 (0)2 - 9790351 Fax: +359 (0) 2 - 9790793
www.herz-bulgaria.bg, office@herz-bulgaria.bg

Herz GmbH

Kunststoff- & Wärmetechnologie
Am Arenberg 26a
DE - 86456 Gablingen
Tel.: +49 (0)8230-85085 Fax: +49 (0)8230-85087
www.herz-gmbh.com, robert.einberger@herz-gmbh.com

Herz Austria GmbH

Kunststoff- & Wärmetechnologie
Johann-Galler-Str. 20 IZ – NÖ - Nord
AT - 2120 Wolkersdorf i. Weinviertel
Tel.: +43 (0)2245-82494-0 Fax: +43 (0)2245-82494-9
www.herz-austria.at, herz.wolkersdorf@herz-gmbh.com

Herz Polska Sp.z o. o.

Technologie obróbki tworzyw sztucznych
ul. Wiernicza 110
PL – 02-952 Warszawa
Tel.: +48 (0)22-8428583 Fax: +48 (0)22-8429700
www.herz-polska.pl, herz.polska@herz-gmbh.com

Half day welding courses in our training facilities - 24 hour repair service.